

Explosion-proof DC motors

Frame: E132

ATEX & IECEx Certified:

I M2 Ex db I Mb

II 2 G Ex db IIB T4 Gb

T amb. -40°C to +60°C



Application

STS explosion proof motors are designed for use where flammable or explosive substances (such as gas vapours or mist) are processed, handled or stored and where during normal operations an explosive or flammable concentration is likely to occur in sufficient quantity to produce a hazard.

The E132 is an explosion proof wound field motor in a 132 frame available in a range of outputs and duty cycles.

Certification

These designs are certified for both gas and mining groups to the ATEX directive 2014/34/EU in compliance with EN60079-0:2018 & EN60079-1:2014 and IECEx in compliance with IEC60079-0:2017 & IEC60079-1:2014.

Insulation Class

Motors are wound with Class H insulation, class F or H rise.

Supply range

24-120V (battery or pure D.C.)

Rating and performance

All motors within this range are assigned ratings in line with the requirements of EN60034-1:2010.

Typical ratings for 1500 RPM motors

Frame	Voltage	Output	Duty
E132-140	110	2.0kW	S2 30 mins
E132-140	120	1.5kW	S1 (MCR)
E132-170	24	1.87kW	S2 120 mins
E132-170	24	1.65kW	S1 (MCR)

Mounting arrangements

Motors are available foot and/or B5 (D type) flange or B14 (C type) face mountings with metric dimensions to IEC72-1. Non-standard mountings are also available. See reverse for dimensions.

Other machines manufactured by STS

ATEX certified DC motors 0.25-10kW

Safe area DC motors 0.25 . 150kW

DC generators and dynamometers.

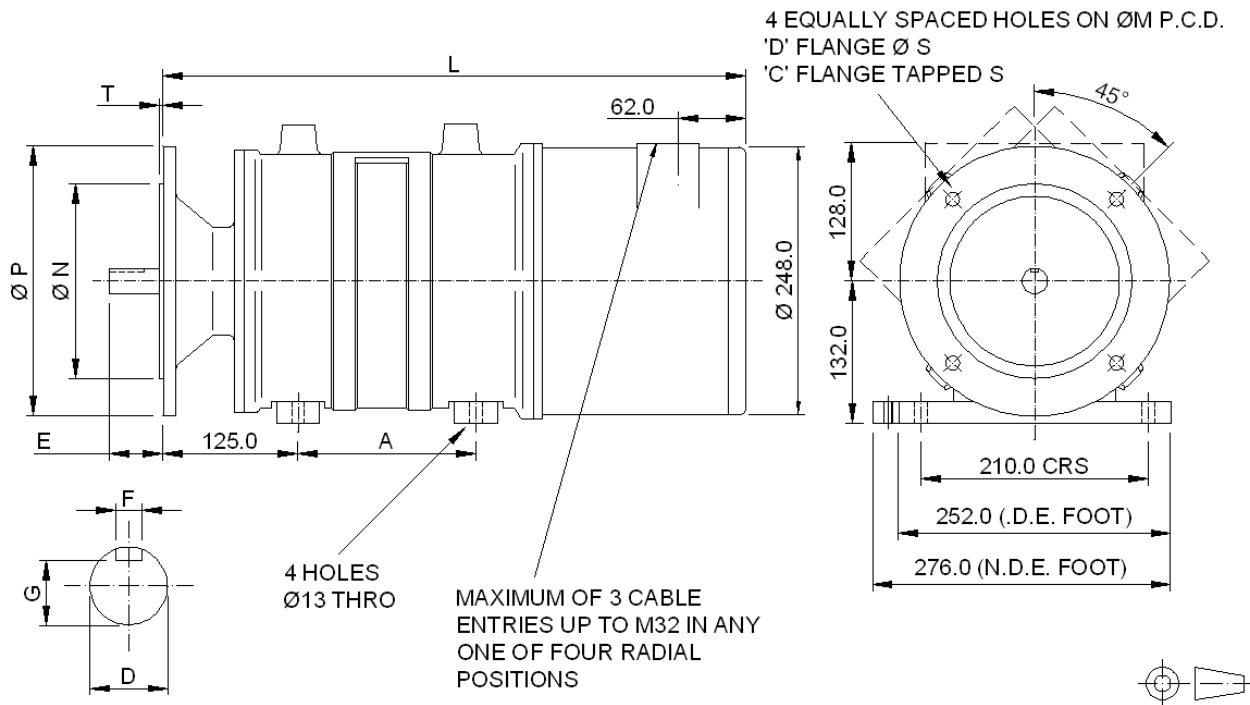

Flange details

Flange size	M	N	P	S	T
FF215 (D100)	215	180	250	15	3.5
FT215 (C160)	215	180	250	M12	3.5

The above dimensions are standard, other sizes are available

Shaft details

D	E	F	G
20	50	6	16.5
24	60	8	20
28	60	8	24

The above dimensions are standard, other sizes are available

Overall dimensions

	Dimensions	
	LB	B
E132S	555	165
E132M	585	195
E132L	615	225